

Genie Super Hoist Specifications

Material Lift

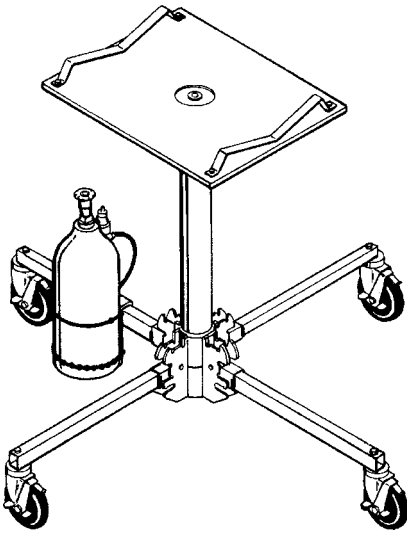

STANDARD FEATURES

- Quick and easy setup
- Auto-lubricating
- Completely portable
- Operates on compressed air or CO₂ bottle
- Easy-to-operate control handle

SPECIFICATIONS

MODEL	GH 3.8	
	US	Metric
Height	41 in	1.04 m
Platform length	19 in	48 cm
Platform width	24 in	61 cm
Base width - corner-to-corner	53 in	1.35 m
Load capacity	300 lb	136 kg
Lifting height	12 ft 5 ⁵ / ₈ in	3.8 m
Dimensions for storage/transport	14 x 14 x 39 1/2 in	36 cm x 36 cm x 1 m
Weight	64 lb	29 kg
Recommended psi	85 psi	5.86 bar

MODEL	GH 5.6	
	US	Metric
Height	54 in	1.37 m
Platform length	19 in	48 cm
Platform width	24 in	61 cm
Base width - corner-to-corner	53 in	1.35 m
Load capacity	250 lb	113 kg
Lifting height	18 ft 4 1/2 in	5.6 m
Dimensions for storage/transport	14 x 14 x 39 1/2 in	36 cm x 36 cm x 1 m
Weight	69 lb	31 kg
Recommended psi	85 psi	5.86 bar

Genie Industries

USA 18340 NE 76th Street
P.O. Box 97030
Redmond, Washington 98073-9730
Telephone (425) 881-1800
Toll Free USA/Canada 800-536-1800
Fax (425) 883-3475
<http://www.genielift.com>

UK The Maltings, Wharf Road
Grantham
Lincolnshire NG31 6BH
Telephone (44) 01476-584333
Fax (44) 01476-584334
<http://www.genielift.com>

Continuous improvement of our products is a Genie policy. Product specifications are subject to change without notice or obligation. The drawings in this brochure are for illustrative purposes only. Refer to the appropriate Genie Super Hoist Operator's Manual for instructions on the proper use of this equipment. Failure to follow the appropriate Operator's Manual when using a Genie Super Hoist, or to otherwise act irresponsibly, may result in serious injury or death. Copyright © 1997 by Genie Industries. "Genie" and "Super Hoist" are Registered Trademarks of Genie Industries in the USA and many other countries. Genie is the owner of US Patents: 5,099,748 and 5,076,521. 2-1-01