

REMS Mini-Amigo REMS Amigo REMS Amigo E REMS Amigo 2 REMS Amigo 2 Compact



deu	Betriebsanleitung
eng	Operating Instructions
fra	Instructions d'emploi
ita	Istruzioni d'uso
spa	Manual de instrucciones
nld	Gebruiksaanwijzing
swe	Bruksanvisning
nor	Bruksanvisning
dan	Betjeningsvejledning
fin	Käyttöohje
por	Manual de instruções
pol	Instrukcja obsługi
ces	Návod k použití
slk	Návod na použitie
hun	Üzemeltetési leírás
hrv	Upute za uporabu
scg	Upute za uporabu
slv	Navodila za uporabo
ron	Instrucțiuni de folosire
rus	Инструкция по эксплуатации
grc	Οδηγίες Χρήσης
tur	Kullanma talimatı
bul	Инструкция за експлоатация
lit	Naudojimo instrukcija
lav	Ekspluatācijas instrukcija
est	Kasutusjuhend

REMS-WERK
Christian Föll und Söhne GmbH
Maschinen- und Werkzeugfabrik
Stuttgarter Straße 83
D-71332 Waiblingen
Telefon +49 (0) 71 51 17 07-0
Telefax +49 (0) 71 51 17 07-110
info@rems.de



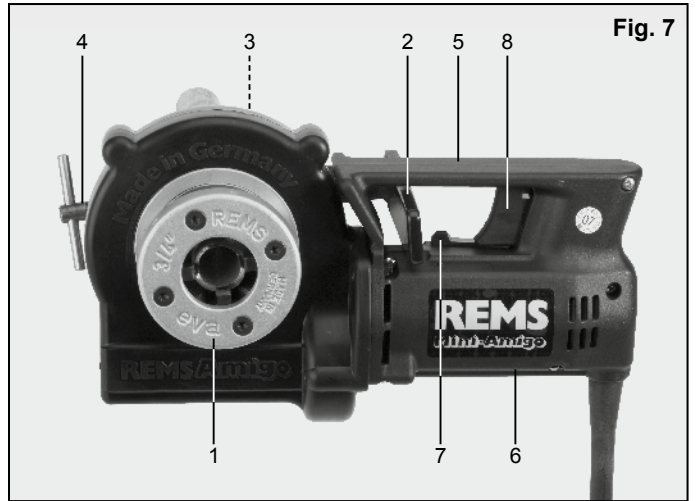
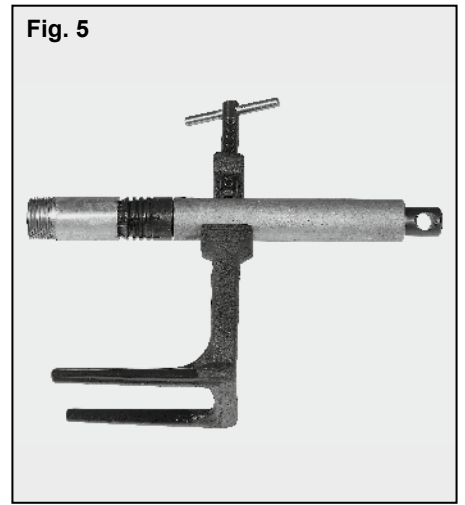
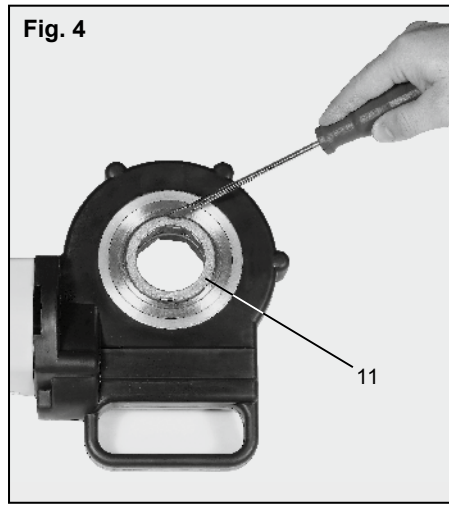
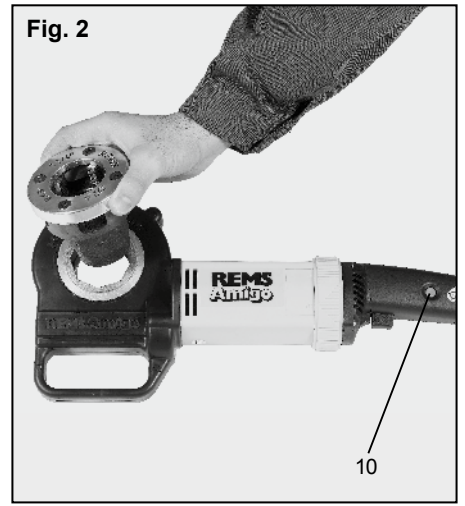
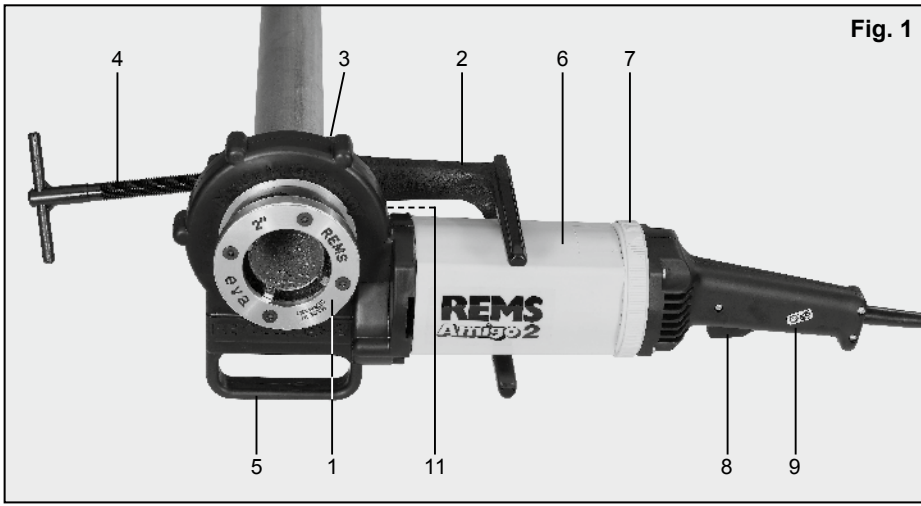

- 5.4. Störung:** Rohr rutscht im Abstützbügel.
Ursache:
- Knebel der Spannschraube zu wenig angezogen.
 - Prismenspannbacken sehr stark verschmutzt oder abgenutzt.
- 5.5. Störung:** Schneidkluppe läuft auf Abstützbügel.
Ursache:
- Rohr zu kurz eingespannt.
 - Gewinde zu lang geschnitten ohne nachzuspannen.
- 5.6. Störung:** Schneidkluppe läuft nicht an.
Ursache:
- Drehrichtungsring/-hebel (7) nicht eingerastet.
 - Überlastschutz (10) hat ausgelöst (REMS Amigo).
 - Anschlußleitung defekt.
 - Antriebsmaschine defekt.

6. Hersteller-Garantie

Die Garantiezeit beträgt 12 Monate nach Übergabe des Neuproduktes an den Erstverwender, höchstens jedoch 24 Monate nach Auslieferung an den Händler. Der Zeitpunkt der Übergabe ist durch die Einsendung der Original-Kaufunterlagen nachzuweisen, welche die Angaben des Kaufdatums und der Produktbezeichnung enthalten müssen. Alle innerhalb der Garantiezeit auftretenden Funktionsfehler, die nachweisbar auf Fertigungs- oder Materialfehler zurückzuführen sind, werden kostenlos beseitigt. Durch die Mängelbeseitigung wird die Garantiezeit für das Produkt weder verlängert noch erneuert. Schäden, die auf natürliche Abnutzung, unsachgemäße Behandlung oder Missbrauch, Missachtung von Betriebsvorschriften, ungeeignete Betriebsmittel, übermäßige Beanspruchung, zweckfremde Verwendung, eigene oder fremde Eingriffe oder andere Gründe, die REMS nicht zu vertreten hat, zurückzuführen sind, sind von der Garantie ausgeschlossen.

Garantieleistungen dürfen nur von einer autorisierten REMS Vertrags-Kundendienstwerkstatt erbracht werden. Beanstandungen werden nur anerkannt, wenn das Produkt ohne vorherige Eingriffe in unzerlegtem Zustand einer autorisierten REMS Vertrags-Kundendienstwerkstatt eingereicht wird. Ersetzte Produkte und Teile gehen in das Eigentum von REMS über.

Die Kosten für die Hin- und Rückfracht trägt der Verwender.

Die gesetzlichen Rechte des Verwenders, insbesondere seine Mängelansprüche gegenüber dem Händler, bleiben unberührt. Diese Hersteller-Garantie gilt nur für Neuprodukte, welche in der Europäischen Union, in Norwegen oder in der Schweiz gekauft werden.

7. REMS Vertrags-Kundendienstwerkstätten

Firmeneigene Fachwerkstatt für Reparaturen:

SERVICE-CENTER

Neue Rommelshäuser Straße 4
D-71332 Waiblingen

Telefon (07151) 56808-60
Telefax (07151) 56808-64

Wir holen Ihre Maschinen und Werkzeuge bei Ihnen ab!
 Nutzen Sie in der Bundesrepublik Deutschland unseren Abholservice.
 Einfach anrufen unter Telefon (07151) 56808-60.
 Oder wenden Sie sich an eine andere autorisierte REMS Vertrags-Kundendienstwerkstatt in Ihrer Nähe.

Teileverzeichnis siehe www.rems.de unter Downloads.

Translation of the original operating instructions

Fig. 1–8

- | | |
|-------------------------------------|---|
| 1 Quick-change die head
REMS eva | 7 Rotation lever |
| 2 Support bracket | 8 Tip switch |
| 3 Prismatic clamping jaw | 9 Motor handle |
| 4 Feed screw | 10 Overload protection
(REMS Amigo) |
| 5 Gear and carrying handle | 11 Retaining ring (REMS Amigo 2/REMS Amigo 2 Compact) |
| 6 Motor | |

General Safety Rules

WARNING! To reduce the risk of injury, user must read and understand instruction manual.

WARNING! Read all instructions. Failure to follow all instructions listed below may result in electric shock, fire and/or serious injury. The term „power tool“ in all of the warnings listed below refers to your mains operated (corded) power tool or battery operated (cordless) power tool, also machines and electric units. Only use the power tool for the purpose for which it was intended, with the due attention to the general safety and accident prevention regulations.

SAVE THESE INSTRUCTIONS.

A) Work area

- Keep work area clean and well lit.** Cluttered and dark areas invite accidents.
- Do not operate power tools in explosive atmospheres, such as in the presence of flammable liquids, gases or dust.** Power tools create sparks which may ignite the dust or fumes.
- Keep children and bystanders away while operating a power tool.** Distractions can cause you to lose control.

B) Electrical safety

- Power tool plugs must match the outlet. Never modify the plug in any way. Do not use any adapter plugs with earthed (grounded) power tools.** Unmodified plugs and matching outlets will reduce risk of electric shock. If the power tool comes with an earthed wire, the plug may only be connected to an earthed receptacle. At work sites, in damp surroundings, in the open or in the case of comparable types of use, only operate the power tool off the mains using a 30 mA fault current protected switch (FI breaker).
- Avoid body contact with earthed or grounded surfaces such as pipes, radiators, ranges and refrigerators.** There is an increased risk of electric shock if your body is earthed or grounded.
- Do not expose power tools to rain or wet conditions.** Water entering a power tool will increase the risk of electric shock.
- Do not abuse the cord. Never use the cord for carrying, pulling or unplugging the power tool. Keep cord away from heat, oil, sharp edges or moving parts.** Damaged or entangled cords increase the risk of electric shock.
- When operating a power tool outdoors, use an extension cord suitable for outdoor use.** Use of a cord suitable for outdoor use reduces the risk of electric shock.

C) Personal safety

- Stay alert, watch what you are doing and use common sense when operating a power tool. Do not use a power tool while you are tired or under the influence of drugs, alcohol or medication.** A moment of inattention while operating power tools may result in serious personal injury.
- Use safety equipment. Always wear eye protection.** Safety equipment such as dust mask, non skid safety shoes, hard hat, or hearing protection used for appropriate conditions will reduce personal injuries.
- Avoid accidental starting. Ensure the switch is in the off position before plugging in.** Carrying power tools with your finger on the switch or plugging in power tools that have the switch on invites accidents.
- Remove any adjusting key or wrench before turning the power tool on.** A wrench or a key left attached to a rotating part of the power tool may result in personal injury.
- Do not overreach. Keep proper footing and balance at all times.** This enables better control of the power tool in unexpected situations.
- Dress properly. Do not wear loose clothing or jewellery. Keep your hair, clothing and gloves away from moving parts.** Loose clothes, jewellery or long hair can be caught in moving parts.
- If devices are provided for the connection of dust extraction and collection facilities, ensure these are connected and properly used.** Use of these devices can reduce dust related hazards.
- Only allow trained personnel to use the power tool.** Apprentices may only operate the power tool when they are over 16, when this is necessary for their training and when they are supervised by a trained operative.

D) Power tool use and care

- Do not force the power tool. Use the correct power tool for your application.** The correct power tool will do the job better and safer at the rate for which it was designed.
- Do not use the power tool if the switch does not turn it on and off.** Any power tool that cannot be controlled with the switch is dangerous and must be repaired.
- Disconnect the plug from the power source before making any adjustments, changing accessories, or storing power tools.** Such preventive safety measures reduce the risk of starting the power tool accidentally.
- Store idle power tools out of the reach of children and do not allow persons unfamiliar with the power tool or these instructions to operate the power tool.** Power tools are dangerous in the hands of untrained users.

- e) **Maintain power tools.** Check for misalignment or binding of moving parts, breakage of parts and any other condition that may affect the power tools operation. If damaged, have the power tool repaired by a qualified expert or by an authorised REMS after-sales service facility before use. Many accidents are caused by poorly maintained power tools.
- f) **Keep cutting tools sharp and clean.** Properly maintained cutting tools with sharp cutting edges are less likely to bind and are easier to control.
- g) **Secure the workpiece.** Use clamps or a vice to hold the workpiece. This is safer than holding it with your hand, and also it frees both hands to operate the equipment.
- h) **Use the power tool, accessories and tool bits etc., in accordance with these instructions and in the manner intended for the particular type of power tool, taking into account the working conditions and the work to be performed.** Use of the power tool for operations different from those intended could result in a hazardous situation. All unauthorised modifications to the power tool are prohibited for safety reasons.
- E) Battery tool use and care**
- a) **Ensure the switch is in the off position before inserting battery pack.** Inserting the battery pack into power tools that have the switch on invites accidents.
- b) **Recharge only with the charger specified by the manufacturer.** A charger that is suitable for one type of battery may create a risk of fire when used with another battery pack.
- c) **Use battery tools only with specifically designated battery packs.** Use of any other battery packs may create a risk of injury and fire.
- d) **When battery pack is not in use, keep it away from other metal objects like paper clips, coins, keys, nails, screws, or other small metal objects that can make a connection from one terminal to another.** Shorting the battery terminals may cause burns or a fire.
- e) **Under abusive conditions, liquid may be ejected from the battery, avoid contact. If contact accidentally occurs, flush with water. If liquid contacts eyes, additionally seek medical help. Liquid ejected from the battery may cause irritation or burns.**
- f) **Do not use the battery/charger at battery/charger temperatures or ambient temperatures of $\leq 5^{\circ}\text{C}/40^{\circ}\text{F}$ or $\geq 40^{\circ}\text{C}/105^{\circ}\text{F}$.**
- g) **Do not dispose defective batteries in the normal domestic waste. Take them to an authorised REMS after-sales service facility or to a reputed waste disposal company.**
- F) Service**
- a) **Have your power tool serviced by a qualified repair person using only identical replacement parts.** This will ensure that the safety of the power tool is maintained.
- b) **Comply with maintenance instructions and instructions on tool replacement.**
- c) **Check mains lead of power tool regularly and have it replaced by a qualified expert or an authorised REMS after-sales service facility in case of damage. Check extension cable regularly and replace it when damaged.**

Specific Safety Instructions

- Use only original REMS eva quick-change die heads! It cannot be assured that other die heads fit securely or they may damage the octagonal seat of the drive unit.
- Always use the support bracket! Otherwise there is a danger of the unit being torn from the hand as the torque increases and spinning round.
- Do not work without retaining ring (11). Otherwise the die head may be pushed out, e.g. during start-cutting.
- Combustible propellant (butane) is added to REMS thread-cutting oils in spray cans (REMS Spezial, REMS Sanitol) which is environment-friendly. Spray cans are pressurized – do not force open. Also, protect them from exposure to strong sunlight and heating above 50°C .
- Due to the degreasing effect of the thread-cutting oils, an intensive skin contact must be avoided. An appropriate skin protector must be applied.
- Do not allow undiluted thread-cutting oil to get into drainage, water systems or the soil. Remaining thread-cutting oils have to be delivered to specialized waste disposal companies. Disposal identity number for mineral-based thread-cutting oils 54401, for synthetic 54109.

1. Technical Data

1.1. Article numbers	REMS Mini-Amigo	REMS Amigo E	REMS Amigo	REMS Amigo 2	REMS Amigo 2 Compact
Drive unit	530001	530003	530000	540000	540001
Guiding support	533100	533000	533000	543000	543010
REMS Dual purpose holder		543100	543100	543100	543100
Die heads for					
pipe threads	R $\frac{1}{8}''$	521000	521000	521000	521000
tapered, right-hand	R $\frac{1}{4}''$	521010	521010	521010	521010
ISO 7-1	R $\frac{3}{8}''$	521020	521020	521020	521020
(DIN 2999, BSPT)	R $\frac{1}{2}''$	521030	521030	521030	521030
	R $\frac{3}{4}''$	521040	521040	521040	521040
	R $1''$	521050	521050	521050	521050
	R $1\frac{1}{4}''$		521060	521060	521060
	R $1\frac{1}{2}''$		521070	521070	
	R $2''$		521080	521080	
1.2. Capacity					
Thread diameters					
Pipes	$\frac{1}{8}'' - \frac{3}{4}''$	$\frac{1}{8}'' - 1''$	$\frac{1}{8}'' - 1\frac{1}{4}''$	$\frac{1}{8}'' - 2''$	$\frac{1}{8}'' - 2''$
Bolt (both)	—	6–30 mm, $\frac{1}{4}'' - 1''$			
Types of threads					
External threads					
right- and left-hand		R (ISO 7-1, DIN 2999, BSPT) NPT			
Pipe threads parallel	—	G (DIN ISO 228, DIN 259, BSPP) NPSM			
(with button die)					
Threads for electric conduit		M \times 1.5 (DIN EN 60423, IEC)			
Pipe threads parallel	—	Pg			
(with button die)					
Bolt threads	—	M, BSW, UNC			
(with button die)					
Thread lengths					
Pipe threads tapered		standard length			
Pipe threads parallel,					
conduit, bolt		50 mm (with reclamping unlimited)			
Nipples and double-nipples with					
the REMS Nippelspanner					
(internal clamping)	$\frac{3}{8}'' - \frac{3}{4}''$	$\frac{3}{8}'' - 1''$	$\frac{3}{8}'' - 1\frac{1}{4}''$	$\frac{3}{8}'' - 2''$	$\frac{3}{8}'' - 2''$
1.3. Revolutions of die head					
Automatically, infinitely					
variable rotation (rpm)	30–18	35–27	35–27	30–18	30–18
1.4. Electrical data					
230 V, 50/60 Hz					
Power input	500 W	950 W	1200 W	1700 W	1200 W
Rated current input	2.3 A	6 A	6 A	8.3 A	6 A
Fuse protection	10 A (B)	10 A (B)	10 A (B)	16 A (B)	10 A (B)
Intermittent service	2/10 min	2/10 min	2/10 min	2/10 min	2/10 min

	REMS Mini-Amigo	REMS Amigo E	REMS Amigo	REMS Amigo 2	REMS Amigo 2 Compact
110 V, 50/60 Hz					
Power input	500 W	950 W	1200 W	1700 W	1200 W
Rated current input	4.6 A	12 A	12 A	16.6 A	12 A
Fuse protection	20 A	20 A	20 A	30 A	20 A
Intermittent service	2/10 min	2/10 min	2/10 min	2/10 min	2/10 min

When cutting taper threads the rated current may increase for a short moment by about 50 %, without interference of the function of the unit.

The drive units REMS Amigo and REMS Amigo 2 Compact are equipped with an overload protection which disconnects the motor when overloaded. In this case, press green button (10) on the motor handle. See also section 5. Troubles.

1.5. Dimensions

L x W x H (mm)	270 x 85 x 160	430 x 80 x 195	440 x 85 x 195	565 x 112 x 237	500 x 90 x 215
	10.6" x 3.3" x 6.3"	16.92" x 3.15" x 7.7"	17.3" x 3.3" x 7.7"	22.2" x 4.4" x 9.3"	19.7" x 3.5" x 8.5"

1.6. Weights

Drive unit	2.7 kg (6.0 lb)	3.4 kg (7.5 lb)	3.5 kg (7.7 lb)	6.5 kg (14.3 lb)	4.9 kg (10.8 lb)
Support	0.6 kg (1.3 lb)	1.3 kg (2.9 lb)	1.3 kg (2.9 lb)	2.9 kg (6.4 lb)	2.6 kg (5.7 lb)
Die heads	0.6 ... 0.7 kg	0.6 ... 0.8 kg	0.6 ... 0.8 kg	0.6 ... 1.3 kg	0.6 ... 1.3 kg
	1.3 ... 1.6 lb	1.3 ... 1.8 lb	1.3 ... 1.8 lb	1.3 ... 2.9 lb	1.3 ... 2.9 lb

1.7. Noise information

Emission at workplace	84 dB (A)	83 dB (A)	83 dB (A)	82 dB (A)	83 dB (A)
-----------------------	-----------	-----------	-----------	-----------	-----------

1.8. Vibrations

Weighted effective value of acceleration	3.5 m/s ²	2.5 m/s ²	2.5 m/s ²	2.5 m/s ²	2.5 m/s ²
--	----------------------	----------------------	----------------------	----------------------	----------------------

The indicated weighted effective value of acceleration has been measured against standard test procedures and can be used by way of comparison with another device. The indicated weighted effective value of acceleration can also be used as a preliminary evaluation of the exposure.

Attention: The indicated weighted effective value of acceleration can differ during operation from the indicated value, dependent on the manner in which the device is used. Dependent upon the actual conditions of use (periodic duty) it may be necessary to establish safety precautions for the protection of the operator.

2. Preparations for Use

2.1. Electrical connection

Before connecting the unit, check whether voltage on the rating plate matches the mains voltage.

2.2. Tools

Use only original quick-change die heads of REMS eva hand die stock. Up to 1¼" diameter the die heads fit the octagonal seat from the front of the drive unit (Fig. 2). They snap-in automatically.

The die heads protrude the back of the housing. This facilitates taking the die head out of the drive unit by jolting the protruding edge against a plain surface or edge (fig. 3).

For inserting the 1" quick-change die head into the REMS Amigo E make sure that the groove in the octagon coincides with the locking pin of the octagonal seat of the REMS Amigo E.

When using the die heads 1½" and 2" with the REMS Amigo 2 and REMS Amigo 2 Compact drive units, take off retaining ring (11) with a suitable tool, e. g. screwdriver. Remove stop ring (Fig. 4), insert 1½" or 2" die head and replace ring (11). **Do not work without retaining ring (11).** Otherwise the die head may be pushed out, e.g. during start-cutting.

Changing dies is necessary when the dies are used or worn or a thread is to be cut on a short piece of pipe. In both cases clamp the die head in a vice, remove cover, then carefully knock out dies from outside to in. Knock in new dies with the start-cutting edge pointing towards the bottom in corresponding slots (die 1 in slot 1, die 2 in slot 2, die 3 in slot 3, die 4 in slot 4) to the extent that they do not project beyond the housing. Install cover, lightly tighten screws. With a soft pin (copper, brass or hard wood) carefully knock out dies carefully outwards until they are in contact with the edge of the cover. Tighten screws securely.

In case a thread is to be cut on a short piece of pipe, use REMS eva quick-change die head S with the additional pipe guidance on the cover side. These need to be operated from the cover side and have to be mounted the other way around. Therefore the dies are to be inserted with the start-cutting side pointing towards the top in following order: die 1 in slot 1, die 2 in slot 4, die 3 in slot 3, die 4 in slot 2.

2.3. Support bracket

The support bracket (2) serves to support the die stock against torque in both directions, i. e. for advance and reverse rotation of the die head, for right and left hand threads. **Support bracket must always be used!**

2.4. Thread-cutting oils

Use only REMS thread-cutting oils. You will have perfect threading results, long durability of dies as well as high protection of the drive unit. REMS recommends the use of the practical and economical spray can.

REMS Spezial: High-alloyed, mineral based thread-cutting oil. **For all materials:** steel, stainless steel, non-ferrous metals, plastics. Pleasant to work with. Washes out with water, approved by experts.

Mineral based thread-cutting oils are not permitted for drinking water installations in some countries, e.g. Germany, Austria and Switzerland. In this case, use the mineral oil-free REMS Sanitol.

REMS Sanitol: Mineral oil-free, synthetic thread-cutting oil for **drinking water supplies.** Completely water-soluble. Complies with regulations: in Germany DVGW Approval No. DW-0201AS2032, in Austria ÖVGW Approval No. W 1.303, in Switzerland SVGW Approval No. 7808-649. Viscosity at -10°C: 190 mPa s (cP). Pumpable to -28°C. No water added. Easy to use. Dyed red for rinse-out inspection.

Both types of thread-cutting oils are available in spray cans as well as in cans and barrels.

Use thread-cutting oils only undiluted!

3. Operation

3.1. Working procedure

Cut pipe/rod at a right angle and burr-free. Fix the support bracket (2) about 10 cm (4") from the end of the pipe (rod) by putting the support bracket from underneath against the pipe (rod) so that it is centered between the prism clamping jaw (3) and the feed screw (4). Tighten the feed screw. Spray REMS thread-cutting oil onto the threading section (see 2.2.). Insert the selected quick-change die head into the drive unit (Fig. 2). Put the unit on the pipe (rod) so that the motor housing (6) is placed inside the bracket.

The bracket (2) of the REMS Mini-Amigo must be positioned between the motor housing and the handle (5) (Fig. 7).

Adjust the rotation lever (7) to the requested rotation (R for right hand threads or reverse rotation for left hand threads, L for left hand threads or reverse rotation for right hand threads). Press tip switch (8) while holding the motor handle (9). Press the gear handle (5) against the material. After 1 or 2 threads, the die heads continues to cut automatically. Lubricate several times with REMS Spray during thread-cutting. The standard length for tapered threads is reached when the front edge of the pipe is flush with the upper edge of the dies (not top of the cover). When the desired thread length is reached, release the tip switch (8). When the unit stops rotating, turn the rotation lever (7) into reverse and by pressing the tip switch (8) again the die head is running off the thread.

Only change the direction on the rotation lever (7) when the unit stops rotating!

3.2. Production of nipples and double nipples

For clamping short pieces of pipes and for the production of nipples and double nipples use REMS Nippelspanner. They are available in sizes from ¾" to 2" For clamping pipe pieces (with or without thread) with the REMS Nippelspanner the head of the Nippelspanner is expanded by turning the spindle with a tool (e.g. screwdriver). This must only be done when a pipe is put on (Fig. 5).

When using the REMS Nippelspanner it must be observed that no shorter nipples are threaded than specified in the standards.

4. Maintenance

Before maintenance work, pull the mains plug!

4.1. Maintenance

The REMS Amigo is maintenance-free. The gearbox has a permanent grease filling and therefore requires no lubrication.

Keep drive unit, quick-change die heads and seating of the drive unit clean. Clean heavily silted die heads, e.g. with turpentine oil.

4.2. Inspection/Service

The motor of the REMS Mini-Amigo/REMS Amigo E/REMS Amigo/REMS Amigo 2/ REMS Amigo 2 Compact has carbon brushes. These are subject to wear and must therefore be inspected or replaced from time to time by an authorised REMS after-sales service facility. See also section 5. Troubles.

5. Troubles

5.1. Trouble: Die stock does not pull through, overload protection (10) triggers off.

- Cause:**
- No original REMS eva die heads.
 - Worn carbon brushes.
 - Blunt dies.
 - Bad quality or too little thread-cutting oil (Use REMS thread-cutting oil).

5.2. Trouble: No workable thread, threads are ripping off.

- Cause:**
- Blunt dies.
 - Bad quality or too little thread-cutting oil (Use REMS thread-cutting oil).

5.3. Trouble: Thread is cut off center.

- Cause:**
- Pipe not cut at a right angle.

5.4. Trouble: Pipe slips inside the support bracket.

- Cause:**
- Feed screw not tightened enough.
 - Prism clamping jaw heavily silted or worn out.

5.5. Trouble: Die stock collides with support bracket.

- Cause:**
- Pipe clamped too short.
 - Thread cut too long without reclamping.

5.6. Trouble: Die stock does not start.

- Cause:**
- Rotation lever (7) not in position.
 - Overload protection (10) has activated (REMS Amigo).
 - Mains lead defective.
 - Drive unit defective.

6. Manufacturer's Warranty

The warranty period shall be 12 months from delivery of the new product to the first user but shall be a maximum of 24 months after delivery to the Dealer. The date of delivery shall be documented by the submission of the original purchase documents, which must include the date of purchase and the designation of the product. All functional defects occurring within the warranty period, which clearly the consequence of defects in production or materials, will be remedied free of charge. The remedy of defects shall not extend or renew the guarantee period for the product. Damage attributable to natural wear and tear, incorrect treatment or misuse, failure to observe the operational instructions, unsuitable operating materials, excessive demand, use for unauthorized purposes, interventions by the Customer or a third party or other reasons, for which REMS is not responsible, shall be excluded from the warranty.

Services under the warranty may only be provided by customer service stations authorized for this purpose by REMS. Complaints will only be accepted if the product is returned to a customer service station authorized by REMS without prior interference in an unassembled condition. Replaced products and parts shall become the property of REMS.

The user shall be responsible for the cost of shipping and returning the product.

The legal rights of users, in particular the right to claim damages from the Dealer, shall not be affected. This manufacturer's warranty shall apply only to new products purchased in the European Union, in Norway or Switzerland.

Spare parts list see www.rems.de under Downloads.

Traduction de la notice d'utilisation originale

Fig. 1-8

1	Tête de filetage à changement rapide REMS eva	7	Inverseur de marche/ Levier inverseur
2	Fourchette d'arrêt	8	Interrupteur
3	Mors à prisme	9	Poignée moteur
4	Vis de serrage	10	Disjoncteur de protection (REMS Amigo)
5	Poignée	11	Circlips (REMS Amigo 2/ REMS Amigo 2 Compact)
6	Moteur		

Remarques générales pour la sécurité

ATTENTION ! Toutes les directives doivent être lues. Le non-respect des instructions présentées ci-après peuvent entraîner un risque de décharge électrique, de brûlures et/ou d'autres blessures graves. Le terme utilisé ci-après « appareil électrique » se réfère aux outils électriques sur secteur (avec câble de réseau), aux outils électriques sur accu (sans câble de réseau), aux machines et aux outils électriques. N'utiliser l'appareil que pour accomplir les tâches pour lesquelles il a été spécialement conçu et conformément aux prescriptions relatives à la sécurité du travail et à la prévention des accidents.

CONSERVER PRECIEUSEMENT CES INSTRUCTIONS

A) Poste de travail

a) **Maintenir le poste de travail propre et rangé.** Le désordre et un poste de travail non éclairé peut être source d'accident.

b) **Ne pas travailler avec l'appareil électrique dans un milieu où il existe un risque d'explosion, notamment en présence de liquides, de gaz ou de poussières inflammables.** Les appareils électriques produisent des étincelles, qui peuvent mettre le feu à la poussière ou aux vapeurs.

c) **Tenir les enfants et des tierces personnes à l'écart pendant l'utilisation de l'appareil électrique.** Il y a un risque de perte de contrôle de la machine en cas de distraction.

B) Sécurité électrique

a) **La fiche mâle de l'appareil électrique doit être appropriée à la prise de courant. La fiche mâle ne doit en aucun cas être modifiée. Ne pas utiliser d'adaptateur de fiche mâle avec un appareil électrique avec mise à la terre.** Des fiches mâles non modifiées et des prises de courant appropriées réduisent le risque d'une décharge électrique. Si l'appareil est doté d'un conducteur de protection, ne brancher la fiche mâle que sur une prise de courant avec mise à la terre. Sur chantier, en plein air ou sur un autre mode d'installation, n'utiliser l'appareil électrique qu'avec un dispositif de protection à courant de défaut de 30 mA (déclencheur par courant de défaut) sur réseau.

b) **Eviter le contact avec des surfaces avec mise à la terre, comme les tubes, radiateurs, cuisinières et réfrigérateurs.** Il y a un risque élevé de décharge électrique lorsque le corps est en contact avec la terre.

c) **Tenir l'appareil électrique à l'écart de la pluie ou de milieux humides.** La pénétration d'eau dans un appareil électrique augmente le risque de décharge électrique.

d) **Ne pas utiliser le câble pour des fins auxquelles il n'a pas été prévu, notamment pour porter l'appareil, l'accrocher ou pour débrancher l'appareil en tirant sur la fiche mâle. Tenir le câble éloigné de la chaleur, de l'huile, des angles vifs et des pièces de l'appareil en mouvement.** Des câbles endommagés ou emmêlés augmentent le risque de décharge électrique.

e) **Si vous travaillez avec l'appareil électrique à l'extérieur, n'utiliser que des rallonges autorisées pour les travaux à l'extérieur.** L'utilisation d'une rallonge appropriée pour l'extérieur réduit le risque de décharge électrique.

C) Sécurité des personnes

a) **Etre attentif, veiller à ce que l'on fait et se mettre au travail avec bon sens si l'on utilise un appareil électrique. Ne pas utiliser l'appareil électrique en étant fatigué ou en étant sous l'influence de drogues, d'alcools ou de médicaments.** Un moment d'inattention lors de l'utilisation de l'appareil peut entraîner des blessures graves.

b) **Porter des équipements de protection individuelle et toujours des lunettes de protection.** Le port d'équipements de protection individuelle, comme un masque respiratoire, des chaussures de sécurité anti-dérapantes, un casque de protection ou une protection acoustique selon le type de l'utilisation de l'appareil électrique, réduit le risque de blessures.

c) **Eviter toute utilisation involontaire ou incontrôlée. Veiller à ce que l'interrupteur soit en position «O» avant l'enfichage sur la prise de courant.** Transporter un appareil électrique avec le doigt sur l'interrupteur ou brancher un appareil en marche au secteur peut entraîner des accidents. Ne jamais pointer un interrupteur.

d) **Eloigner les outils de réglage ou tournevis, avant la mise en service de l'appareil électrique.** Un outil ou une clé se trouvant dans une pièce de l'appareil en mouvement peut entraîner des blessures. Ne jamais approcher la main de pièces en mouvement (tournantes).

e) **Ne pas se sur-estimer. Veiller à une position sûre et garder l'équilibre à tout moment.** De ce fait, l'appareil peut être mieux contrôlé dans des situations inattendues.

f) **Porter des vêtements appropriés. Ne pas porter de vêtements amples, ni de bijoux. Ecarter les cheveux, les vêtements et les gants des pièces en mouvement.** Des vêtements amples, des bijoux ou des cheveux longs pourraient être happés par des pièces en mouvement.

g) **Si des dispositifs d'aspiration et de réception de poussière peuvent être montés, veiller à ce qu'ils soient branchés et utilisés correctement.** L'utili-