

No. 3-S

Capacity: 2", through 3"

No. 4-S

Capacity: 2", through 4"

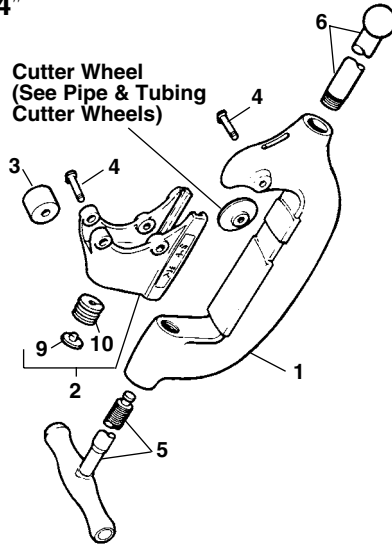

No. 6-S

Capacity: 4" through 6"

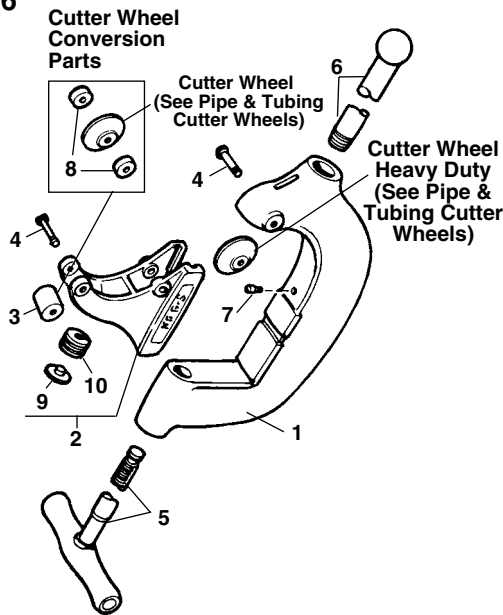

NOTE: Order parts by Catalog Number only.
DO NOT order by Reference Number.

	3-S 1"-3"	4-S 2"-4"	6-S 4"-6"
Ref. No. Description	Catalog No.	Catalog No.	Catalog No.
1 Frame	33285	33280	33275
2 Roll Housing	33390	33385	33300
3 Roll (2)	34785	34785	34785
4 Pin (3)	34790	34790	34790
5 Screw Handle	33515	33515	33515
6 Pipe Handle	35030	35030	35030
7 Stop Screw			34425
8 Wheel Spacer (2)			34855
9 Wear Plug	34320	34320	34320
10 Wear Plug Spring	34315	34315	34315

No. 42-A

Capacity: 1/2" through 2" O.D.

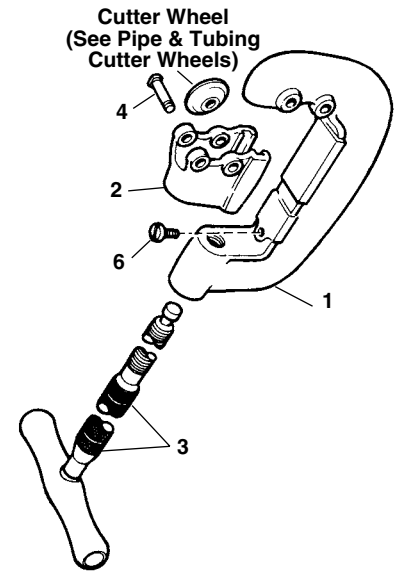

No. 44-S

Capacity: 2 1/2" through 4" O.D.

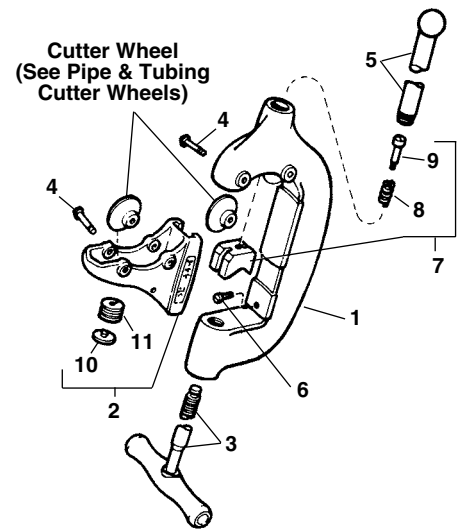

	42-A 1/2"-2"	44-S 2 1/2"-4"
Ref. No. Description	Catalog No.	Catalog No.
1 Frame	33295	33270
2 Cutter Wheel Housing	33455	33345
3 Screw Handle	33590	33515
4 Wheel Pin (4)	34780	34790
5 Pipe Handle		35030
6 Stop Screw	34425	34425
7 Guide Block Assembly		34840
8 Spring		34850
9 Shoulder Screw		34845
10 Wear Plug		34320
11 Wear Plug Spring		34315